



WAREWASHING
CART WASHER

SERIES WWA





WE OFFER YOU THE PERFECT SOLUTION

Thanks to our decades of know-how as warewashing manufacturers, and our modular system, we are able to offer our customers tailor-made, complete solutions. They not only adjust to the customer's spatial situation but also fulfill every capacity requirement.

YOUR ADVANTAGES:

- Tailored complete solutions
- Premium hygiene and process reliability
- Reliable technology "Made in Germany"



MADE IN GERMANY





For a long time, and to this day, „Made in Germany“ has been a mark of quality and reliability for premium quality segments.

But a company only holds its ground if it delivers on its promises and produces high quality permanently.

OUR MODELS

HOBART cart washers offer premium **hygiene and process reliability** to companies operating hospitals, or other large facilities.

The HOBART product portfolio offers single- and multi-chamber cart washers which can be flexibly adapted to our customers' requirements.

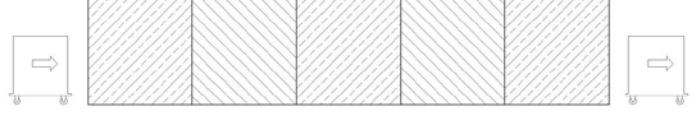
DESIGNATION	NUMBER OF CHAMBERS	CAPACITY/H	REPRESENTATION
WWA 15-1K	1	15 – 30 trolleys*	
WWA 20-2K	2	20 trolleys	
WWA 30-3K	3	30 trolleys	
WWA 40-5K	5	40 trolleys	

* Depending on the size of the carts to be washed, the simultaneous washing of up to three carts is possible which increases the capacity of the system.

Single-chamber cart washer WWA-15-1K

All the steps involved in the process of hygienically cleaning the carts take place within one single chamber: washing, rinsing, and drying.





RELIABLE HYGIENE AT ALL TIMES

SAFE DECONTAMINATION

Reliable hygiene thanks to chemical-thermal treatment.

The combination of the guaranteed process temperatures and the chemistry used ensures a germ reduction of at least 5 log steps on the treated material.



POWERFUL DRYING

Up to five drying blowers ensure not only low-noise but also highly efficient drying of the treated items in accordance with the requirements of the AK-BWA*.

Depending on the geometry of the transport carts to be washed, water may collect on the chassis. The optional underfloor blow-drying unit reduces water accumulation and optimises the drying result.



SMART INCLINATION

The inclination of the transport trolley of 5° allows the rinse water to drain fully, ensuring even faster drying.



* AK-BWA: Working Group for Bedframe and Trolley Decontamination Systems

WASH PERFORMANCE

ACTIVE WASH SYSTEM

Because of the flexible movement of the entire washing and rinse arms and the individually adjustable stainless steel ball nozzles, all the surfaces of the treated items are sprayed and cleaned. Furthermore, separate water supply routes for cleaning and rinsing prevent cross-contamination within the system.

This way, the system ensures optimum results pursuant to the specifications of the AK-BWA for any size of transport cart.



RELIABLE SYSTEM

All HOBART systems are the result of on many years of competence and know-how within the warewashing industry: developed, designed and manufactured "Made in Germany".

COMFORT

PROTRONIC XL

For handling and hygiene control, the innovate PROTRONIC XL control is much more advanced than previous controls, which greatly simplifies the operation, documentation and control of the machine.

The self-explanatory user interface assists the operator in quickly finding their way around the clearly laid out touch screen. All key hygiene related information and functions become visible at a glance.

The PROTRONIC XL control is also installed in the HOBART rack-type and flight-type dishwashers, offering the user a uniform user interface in all areas.





COMFORT

EVERYTHING AT A GLANCE

A large viewing window and the illuminated interior enable comfortable functional checks and visual inspection of the powerful decontamination process.

SAFETY

The emergency-stop rip cord in the interior allows for safe access to the system.

EFFICIENT SPARE PARTS MANAGEMENT

Since HOBART warewashing systems and HOBART cart washers use components of the same design, the ready availability of spare parts is guaranteed.

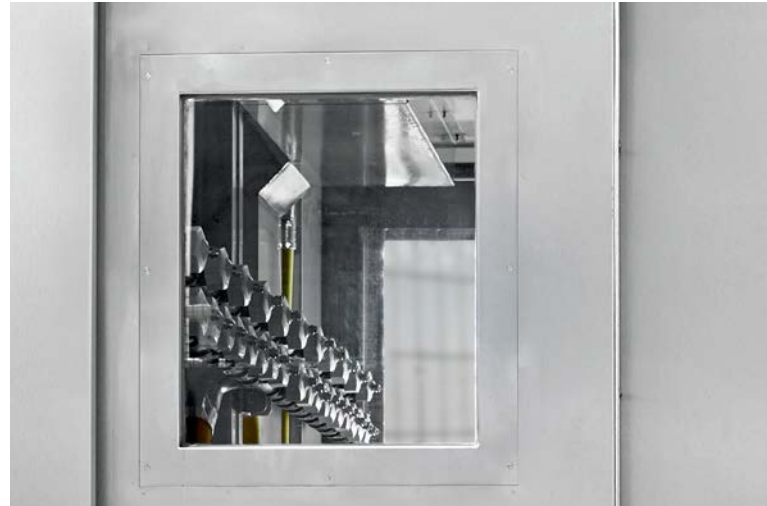

SLIDING DOORS FOR A SMALL FOOTPRINT

The compact HOBART cart washers boast automatic sliding doors. Compared to hinged doors, this system not only saves space but also facilitates loading and unloading of the machine and allows for automatic loading. Another benefit of

the sliding doors is that, unlike the roller shutter doors, no water is accumulated in the door, thus preventing any water dripping down.



FLEXIBILITY

MODULAR SYSTEM

The modular system offers tailored solutions and the ideal product for every capacity requirement and spatial situation.

Independent installation types

The machine can be installed on site either on floor level or lowered in a pit.

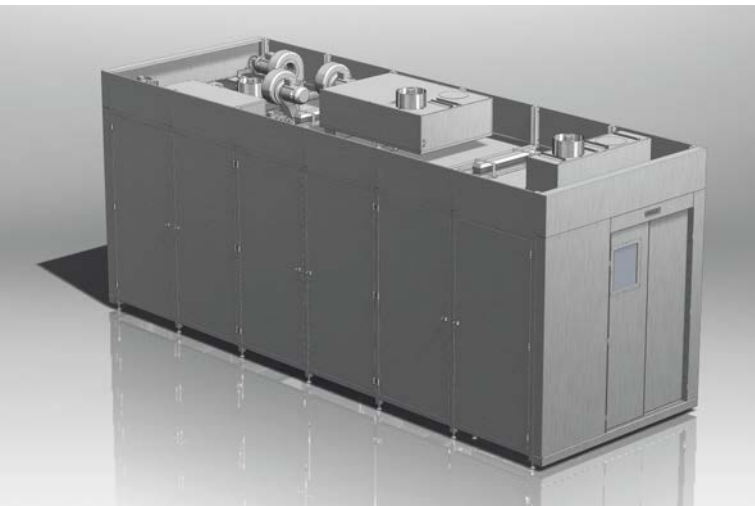

SELECTABLE DEGREE OF AUTOMATION

The carts can be fed to the machine by hand or automated by means of conveyors:

- Automated Guided Systems (AGS)
- Electrical overhead tracks (EOT)
- Automatic goods transport systems (AGT)
- Belt conveyors



Automated Guided System

INDEPENDENT CONVEYOR TECHNOLOGY FOR MULTI-CHAMBER SYSTEMS

The carrier of the chain conveyor system can be individually adapted to your cart type.



Electrical overhead track

SAMPLE DRAWINGS

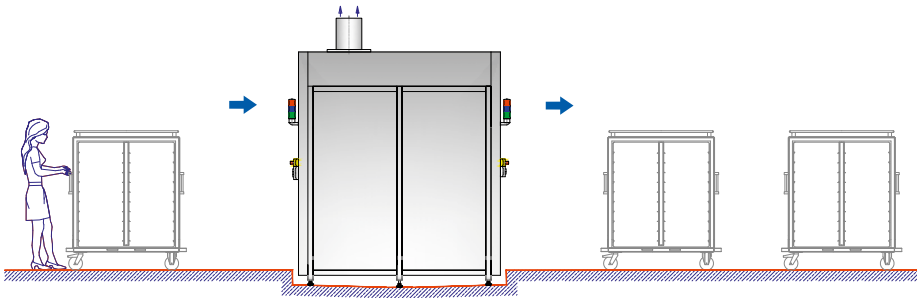

Single-chamber system in pit installation

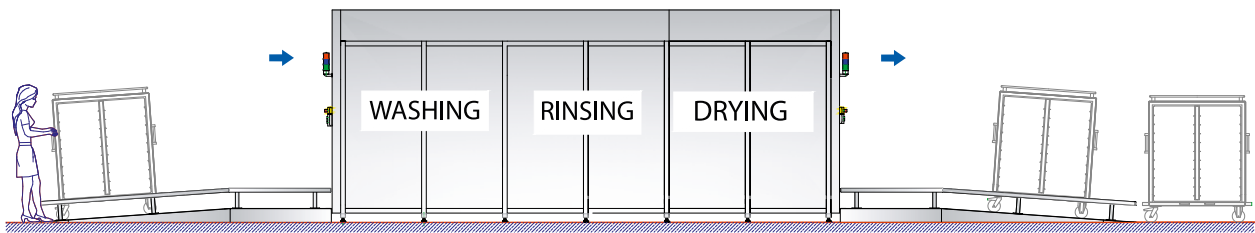

Multi-chamber system in floor-level installation

Single-chamber cart washer
WWA 15-1K

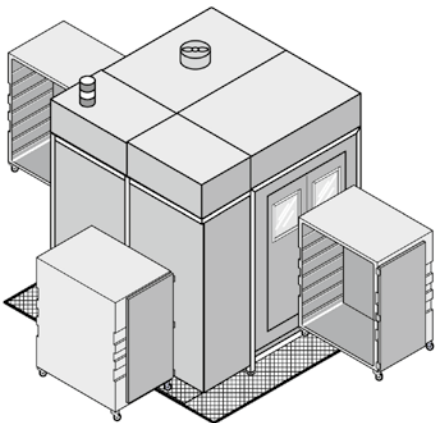

Two-chamber cart washer
WWA 20-2K

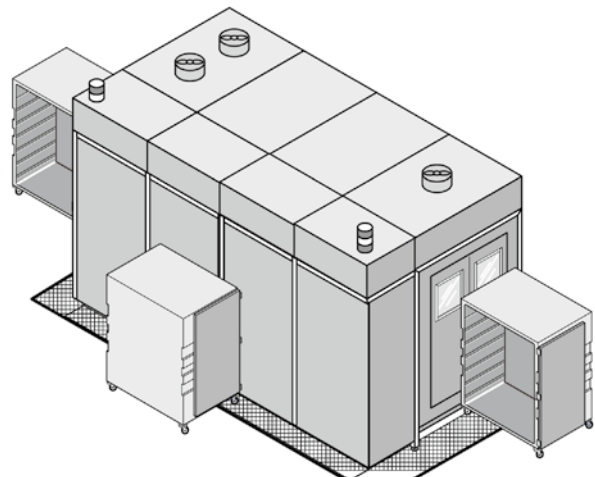

TECHNICAL SPECIFICATIONS

MODEL	WWA 15-1K		WWA 20-2K	WWA 30-3K	WWA 40-5K
Machine type	Push-in machine	Pass-through machine	Pass-through machine	Pass-through machine	Pass-through machine
Cycle time in min	4	4	3	2	1.5
Number of chambers	1	1	2	3	5
Capacity/h of the machine	15 - 30	15 - 30	20	30	40
DIMENSION in mm					
Length	2,280	2,390	4,440	6,520	10,700
Height	2,700	2,700	2,700	2,700	2,700
Width	2,265	2,265	2,265	2,265	2,265
USABLE INTERIOR SPACE in mm/chamber*					
Length	1,800	1,800	1,800	1,800	1,800
Height	1,900	1,900	1,900	1,900	1,900
Width	960	960	960	960	960
CONNECTED LOADS					
Electrically heated**	approx. 96 kW	approx. 96 kW	approx. 157 kW	on request	on request
FRESH WATER CONSUMPTION in l/trolley					
	18	18	18	18	18

* Standard dimensions. Extra-wide / extra-high versions available on request.

** Heating also possible by steam or hot water; values on request

Thanks to the mobile wash system and the independent conveyor system, the WWA series is suitable for all commercially available cart types by different manufacturers.





THE COMPANY

HOBART is the world market leader for commercial warewashing technology and well known manufacturer of cooking, food preparation, and environmental technology. Established in 1897 in Troy, Ohio, today HOBART employs more than 6,900 employees around the world. At our manufacturing plant in Offenburg, Germany, HOBART develops, produces, and distributes warewashing technology worldwide. The hotel and catering trade, cafeterias, bakeries and butcher shops, supermarkets, airlines, cruise ships, automotive suppliers, research centres and pharmaceutical companies all over the world swear by our innovative products, which are considered to be economical and ecological market leaders.

OUR FOCUS

INNOVATIVE - ECONOMICAL - ECOLOGICAL

This is our philosophy. To us, innovation means continuously setting new standards in technology, combined with real added value for the customer. Our group's Technological Centre, and our own Innovation Centre for Warewashing Technology at our headquarters in Germany, make this possible. Here, our innovative powers are combined to create highly efficient products which continuously confirm our status as technological leader. To be economical means to set standards in terms of the lowest operating costs and minimal use of resources, and to revolutionise the market continuously. To be ecological means responsible handling of resources and a sustainable energy policy. This applies not only to the product in use, but in general to all areas of the organisation, such as purchasing or manufacturing.

WHEN THE FIRST MACHINE
IS FINALLY CAPABLE OF
WASHING WITHOUT WATER,
IT WILL BE A HOBART.

We provide this promise of quality to our customers,
and it represents our personal standard upheld
by all our staff at HOBART.

OUR VISION – WASH WITHOUT WATER

Intensive market research has shown that our customers expect warewashing technology that combines efficiency with optimal performance. We are focused on meeting these demands, and they form the foundation for our vision to "wash without water". This vision is our continuous incentive to break new ground in order to constantly reduce the consumption of water, energy and chemicals. We continue pursuing this goal methodically and with the most innovative engineering. Indeed, we already know that: When the first machine is finally capable of washing without water, it will be a HOBART.

HOBART COMPETENT - FAST - RELIABLE

HOBART service technicians and HOBART service partners are the "real" experts. Thanks to intensive training and many years of experience, they have a unique and profound knowledge of the products. This means that maintenance and repair work is always carried out professionally, fast and reliably.



**DEUTSCHLAND/ÖSTERREICH****HOBART GMBH**

Robert-Bosch-Straße 17 | 77656 Offenburg
Tel.: +49(0)781.600-0 | Fax: +49(0)781.600-23 19
info@hobart.de | www.hobart.de

 Werkkundendienst 0180.345 62 58
für Österreich 0820.24 05 99

Zentraler Verkauf 0180.300 00 68

NEDERLAND**HOBART NEDERLAND B.V.**

Pompromenlaan 12 | 3447GK Woerden
Tel.: +31(0)348.46 26 26
Fax: +31(0)348-43 01 17
info@hobart.nl
www.hobart.nl

KOREA**HOBART KOREA LLC**

7th Floor | Woonsan Bldg | 108 | Bangi-dong
Songpa-gu | Seoul 138-050
Phone: +82(0)2 34 43 69 01
Fax: +82(0)2 34 43 69 05
contact@hobart.co.kr
www.hobart.co.kr

SCHWEIZ**GEHRIG GROUP AG**

Bäulerwisenstrasse 1 | 8152 Glattbrugg
Tel.: +41(0)43.211 56-56
Fax: +41(0)43.211 56-99
info@gehriggroup.ch
www.gehriggroup.ch

NORGE**HOBART NORGE**

Gamle Drammensvei 120 A | 1363 HØVIK
Tel.: +47 67 10 98 00
Fax: +47 67 10 98 01
post@hobart.no
www.hobart.no

JAPAN**HOBART (JAPAN) K.K.**

Suzunaka Building Omori
6-16-16 Minami-Oi | Shinagawa-ku | Tokyo 140-0013
Phone: +81(0)3 5767 8670
Fax: +81(0)3 5767 8675
info@hobart.co.jp
www.hobart.co.jp

FRANCE**COMPAGNIE HOBART**

ZI PARIS EST - Allée du 1er Mai - B.P. 68
77312 MARNE LA VALLEE Cedex 2
Téléphone: +33(0)1 64 11 60 00
Fax: +33(0)1 64 11 60 01
contact@hobart.fr
www.hobart.fr

SVERIGE**HOBART SCANDINAVIA APS**

Varuvägen 9 | 125 30 Älvsjö
Tel.: +46 8 584 50 920
Fax: +46 8 584 50 929
info@hobart.se
www.hobart.se

SINGAPORE**HOBART INTERNATIONAL (S) PTE LTD**

158 | Kallang Way | #06-03/05
Singapore 349245
Phone: +65(0)6846 7117
Fax: +65(0)6846 0991
enquiry@hobart.com.sg
www.hobart.com.sg

UNITED KINGDOM**HOBART UK**

Southgate Way | Orton Southgate
Peterborough | PE2 6GN
Phone: +44(0)844 888 7777
customer.support@hobartuk.com
www.hobartuk.com

DANMARK**HOBART SCANDINAVIA APS**

Håndværkerbyen 27 | 2670 Greve
Tel.: +45 43 90 50 12
Fax: +45 43 90 50 02
post@hobart.dk
www.hobart.dk

THAILAND**HOBART (THAILAND)**

43 Thai CC Tower Building | 31st FL
Room No. 310-311 | South Sathorn Rd.
Yannawa | Sathorn | Bangkok | 10120
Phone: +66(0)2-675-6279-81 | Fax: +66(0)2-675-6282
enquiry@hobartthailand.com | www.hobartthailand.com

BELGIUM**HOBART FOSTER BELGIUM**

Industriestraat 6 | 1910 Kampenhout
Phone: +32(0)16 60 60 40
Fax: +32(0)16 60 59 88
sales@hobart.be
www.hobart.be

AUSTRALIA**HOBART FOOD EQUIPMENT**

Unit 1 / 2 Picken Street | Silverwater NSW | 2128
Tel.: +61(0)2 9714 0200
Fax: +61(0)2 9714 0242
www.hobartfood.com.au

OTHER COUNTRIES**HOBART GMBH**

Robert-Bosch-Straße 17 | 77656 Offenburg | Germany
Phone: +49(0)781.600-28 20
Fax: +49(0)781.600-28 19
info-export@hobart.de
www.hobart-export.com

Die Angaben in diesem Prospekt beruhen auf dem Stand 07/2018. Technische Änderungen oder Änderungen der Ausführung bleiben vorbehalten.

The details given in this brochure are correct as of 07/2018. We reserve the right to technical or design modifications.

Document non contractuel. Les indications de ce prospectus sont conformes à la mise à jour de 07/2018. Nous nous réservons le droit de modifier les données ou les configurations techniques de nos machines.

